

The Decibel 43

The Decibel program started in 2016 and began as an experimental project with a directive to explore how sound attenuation properties could be achieved within thin structural panels.

Since then we have embarked on a journey of design trials and numerous prototype tests to fine-tune the narrative and application of this product. This system was designed with architects and space planners in mind, to offer them the flexibility to plan large open spaces with acoustic privacy and the tools to personalise the system, so that their project could have its own unique look. As its chief function is to create acoustic comfort, we named the system Decibel, the unit for measuring sound.

Decibel 43 seamlessly combines furniture and Micro-Architecture. The elements create versatile space division and enclosures while keeping the overall feel of an open and social environment. They are designed to work together individually and collectively to create practical spatial concepts for group collaboration and individual privacy to optimise your office's productivity and creativity.

Led by purpose, backed by research, and driven by design, Decibel 43 will help you design great spaces so that we can work better.

Aditya Vernekar
Senior Industrial Designer

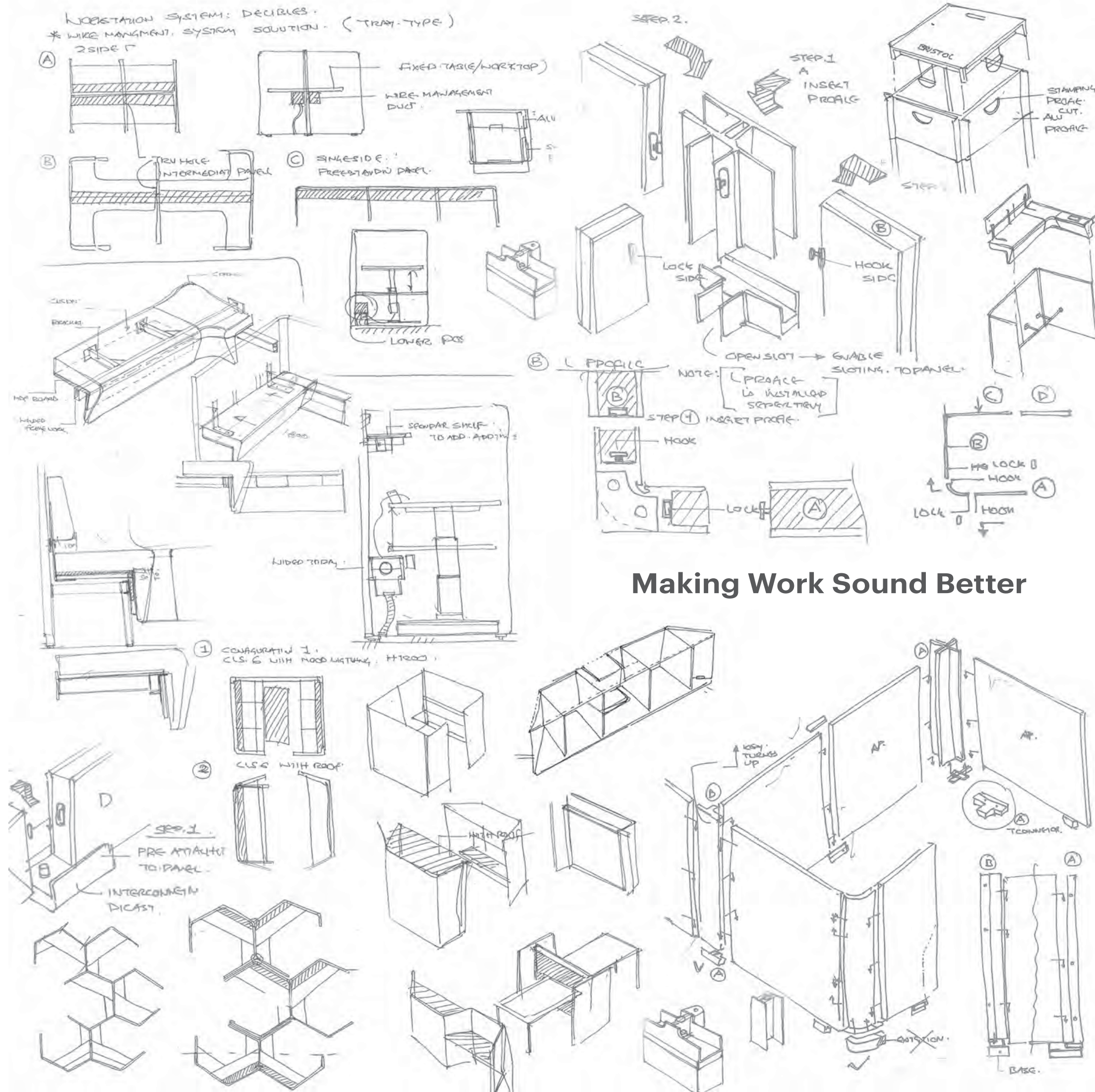

Making Work Sound Better



WPC-6-B



WPC-2-K

Work Pod Cubic

Working alone or together, people seek inspiring functional spaces. Work Pods provide single or multiple private workspaces, that can be configured in Cubic, Hex and Wave configurations, which can help create zones for different work applications.

All Work Pods provide architects and planners with options to create interesting spaces and layouts, allowing for more specificity. They can be optionally equipped with wire management solutions, electrical modules and personalised with accessories to suit individual needs. Work Pods are easily installed to create micro-architecture within open spaces - microcosms of privacy in the busiest surroundings.

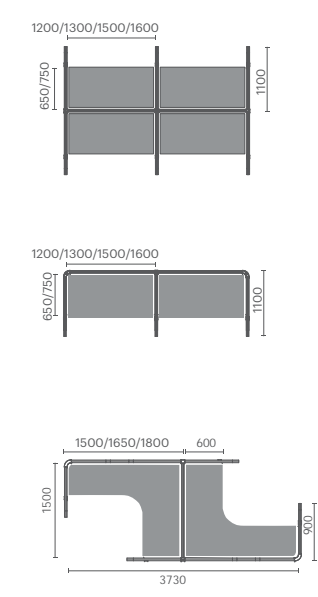

Work Pod Wave

Work Pod Wave works well for bifurcating spaces in busy areas and provides enhanced acoustic attenuation for public areas.

Designed to have smaller footprint, it is also perfect for hot deskers and digital nomads.



Work Pod Hex (Independent)

There is one thing that all organisations have in common: change. With this in mind, we designed the Work Pod Hex to be flexible for the planner to build large fixed type configurations, in sharing or individual modules to create a similar and seamless spatial layout.



WPH-1-A

WPH-2-A

WPH-2-A

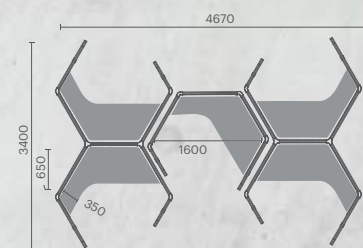

Independent Modules

Bring independent Work Pod Hexes together to form a honeycomb structure that fits together snugly but has the benefit of flexibility for any future changes.

Work Pod Hex (Interdependent)



WPH-5-A

Interdependent Modules

Create interdependent large structures with Work Pod Hex. Here you can build multiple modules that share the same panel, for cost and space effectiveness.

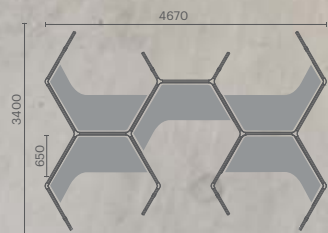



Meeting Pod

It provides the option to create a 'room-within-a-room' for acoustic and visual privacy which can be fully integrated with media, data and electrical management.

The unit can serve as a video conference, presentation or meeting room- allowing privacy without isolation. The Meeting pods are offered in various sizes and can be fitted with fixed tables.



MP-6-A1

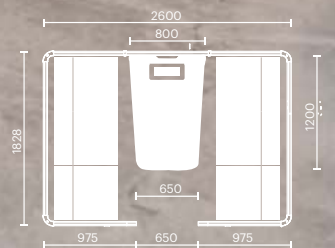

Media Hub

Essential for private communication in public areas, the Media Hub provides a collaborative workspace for meeting in formal or casual contexts. Tall acoustic panels keep conversations in check and visual distractions out. The panel allows media and electrical integration. The acoustic panel is also with height adjustable meeting table.

The unit can spontaneously serve as a video conference area or a quiet spot for a meeting while avoiding congestions typically felt in walled zones. Height adjustable table is available as an option. The table can be controlled via RFID Remote Control or Control Panel.



MH-W-HT

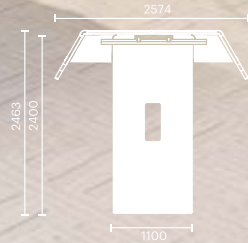

MH-W-OO

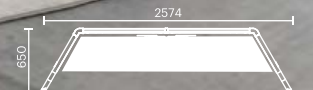

700-1200

Integration of media hub with a height adjustable table.



This intuitive wireless remote enables you to adjust the height of the table, from any surface within a 5 meter radius.



The control panel to raise or lower the height of the worksurface. The control panel has a display for height read-out and memory to store favourite positions.

Seat Pod

Create a lounge-based setting that facilitates casual collaboration and social connection. The back screen of the Seat Pod creates a versatile space division and enclosure while keeping the overall feel of an open, social environment.



SPW-2-O

SPW-3-O

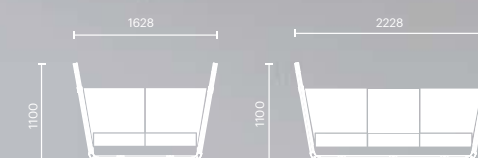

Parts To Help You Plan Better

BUILD YOUR OWN

Applied to the fluidity of co-working spaces or fixed traditional work areas, the Decibel System has connectors to allow designers to create customised layouts that make public spaces private – whether for individual concentration or collaboration among work

groups. Designed to depart from typical rigid office plans, the modules add definition and structure to an office landscape.



L90 Connector

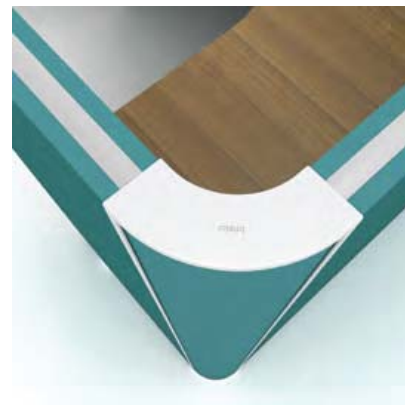

R100 L90 Connector



R100 L100 Connector

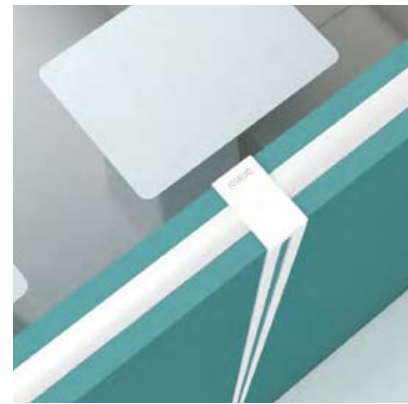

Inter Connector



R100 L120 Connector



T Connector



120° 3 Ways Connector

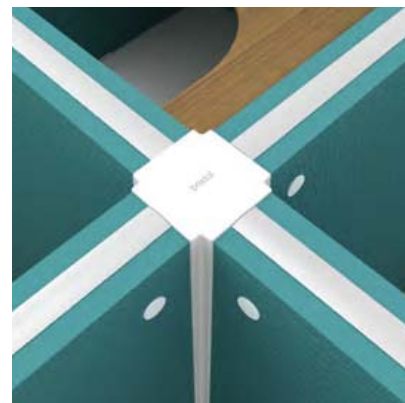

Cross Connector

Improved Acoustics At Work



COLLABORATION

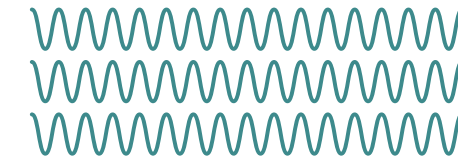

sound waves



DISTRACTED



COLLABORATION

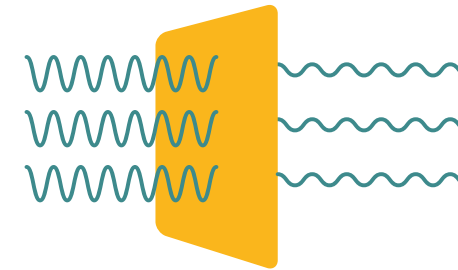

Decibel panel

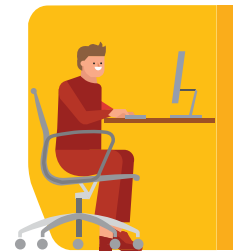

FOCUSED

High traffic areas in offices require effective acoustics and appropriate sound absorbing baffles to diffuse distracting sounds. In today's open plan offices, the introduction of office furniture with acoustic attenuation properties can dramatically aid in effective sound reduction, and reduce the overall perception of noise transmission by 50%.

Indicative NRC Values for 1500g/m² 9mm material are as follows:

- 0.35 NRC with no air-gap
- 0.55 NRC for 18-25mm air gap
- 0.75 NRC for air gap of 50mm and above

*NRC=Noise Reduction Coefficient

With polyester felt MDF laminated panels with air gap construction, Decibel 43 systems provide effective noise reduction, whereby the reverberation time can be reduced by an average of 60%-65% in the relevant frequency range of 200-2000Hz.

Disclaimer Note: NRC values of a material are fixed, depending upon their construction and its material property. However, different NRC values can be achieved and the cumulative effect of noise reduction of a space may vary/differ. This depends on various other factors associated within the space and also on application and position of sound absorbing elements.

Accessories And Branding

Each system can be personalised precisely to the user's individual needs with accessories like multi-level shelves, caddies to keep personal items neatly away, a personal whiteboard, document organisers of varying sizes, rotating tables and filing shelves. To add the ultimate hallmark, your company logo, user name, serial number can also be inscribed.

* Additional costs and lead time may apply depending on the level of personalisation.



Multi Shelving



Whiteboard



Document Folder



Organizer



Filing



Caddy



Rotating Table



Graphic stickers to give corporate identity. Printed on 3M vinyl stickers.



Company logo with laser engraving.

Types of Side Panel Profiles

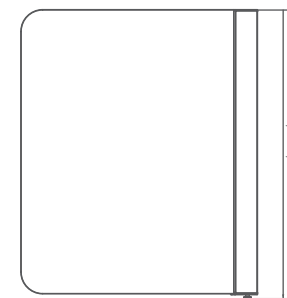

TYPE A

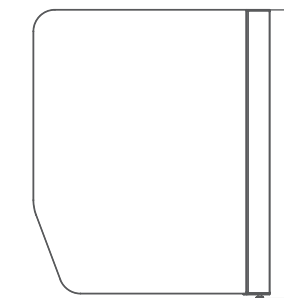

TYPE B

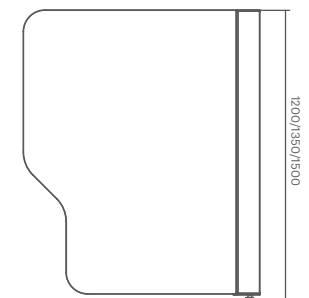

TYPE C



Seatpod

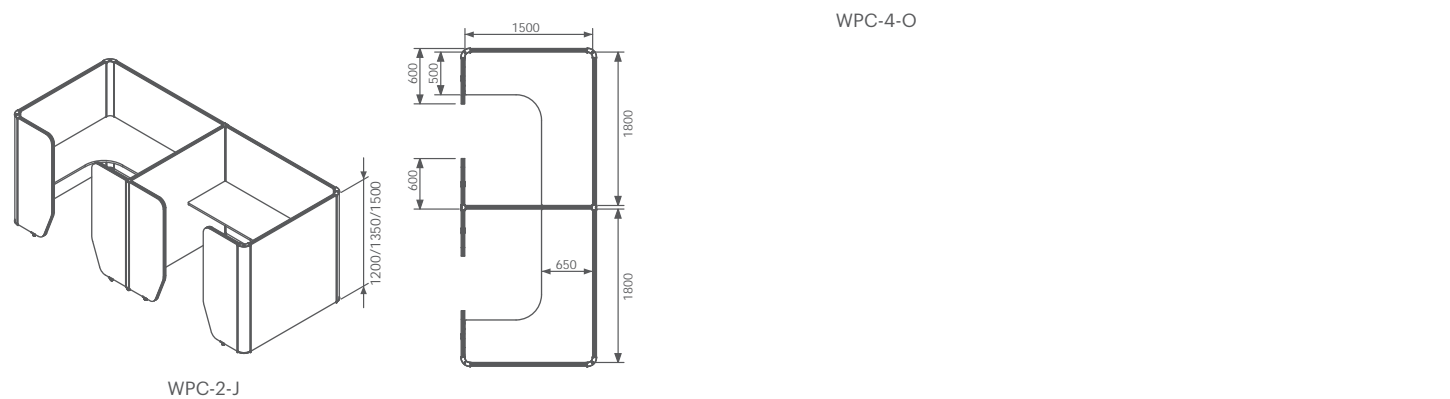
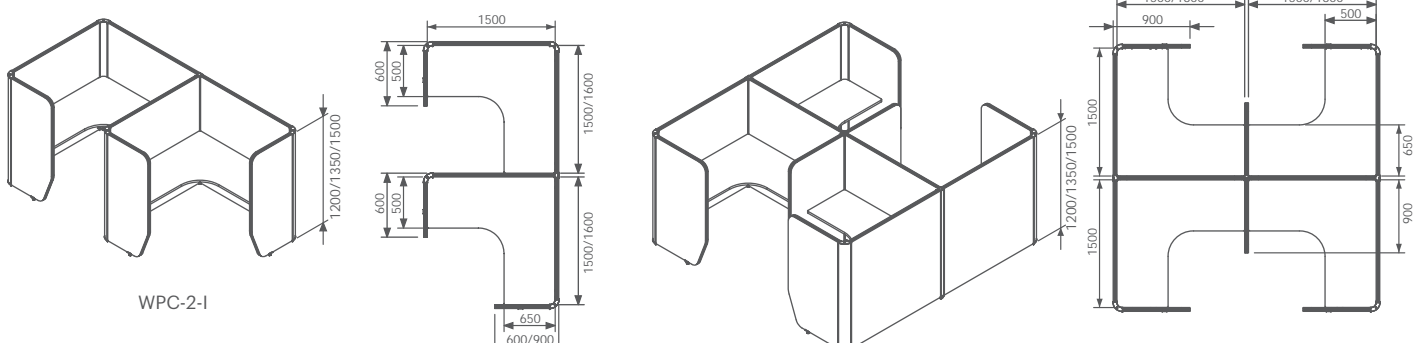
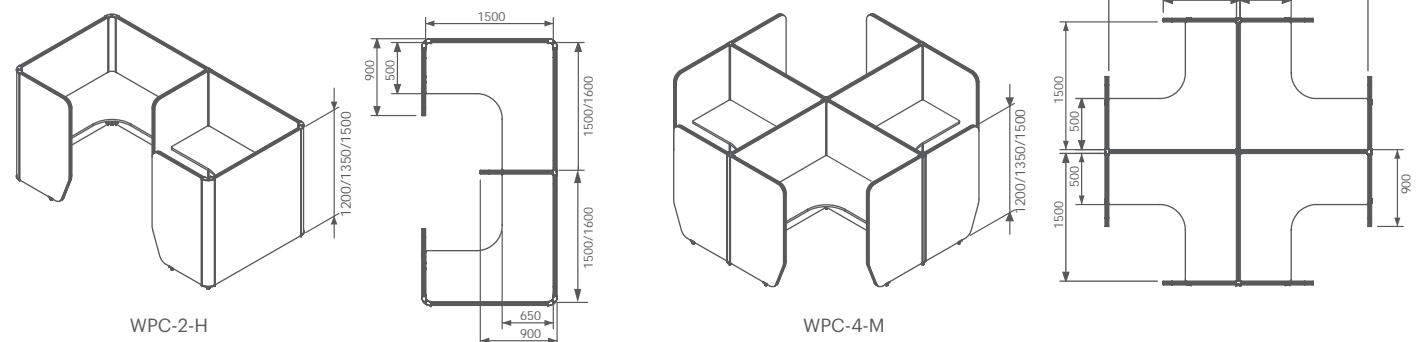
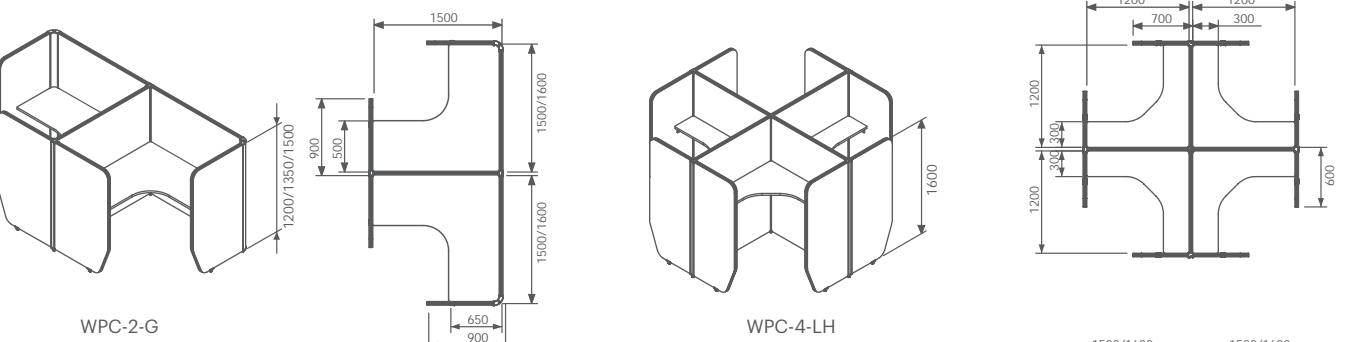
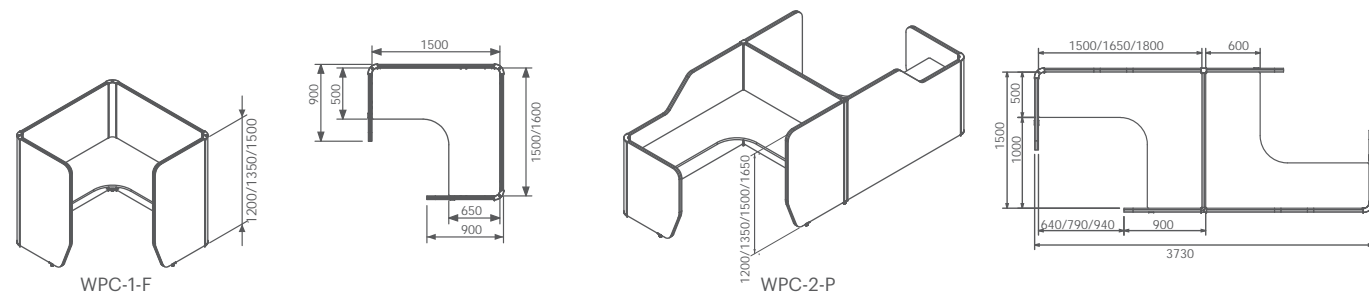
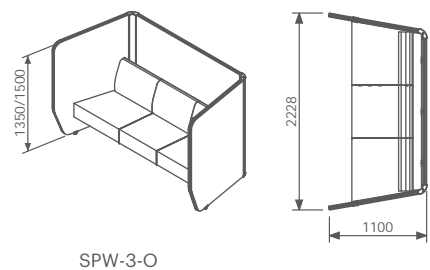
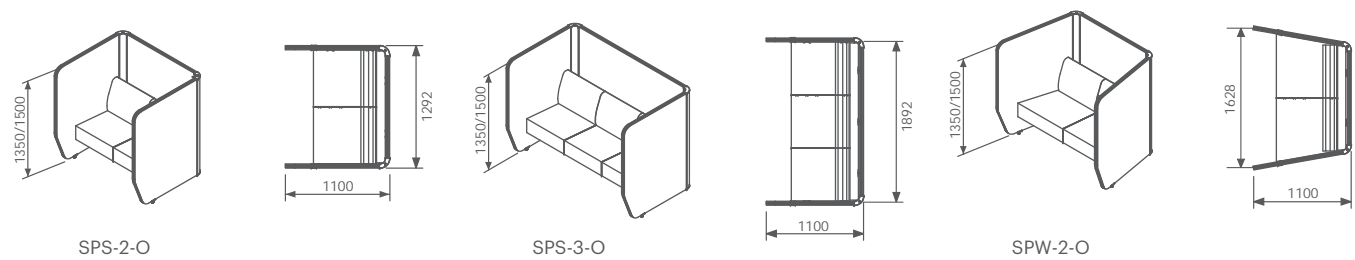

Workpod Cubic

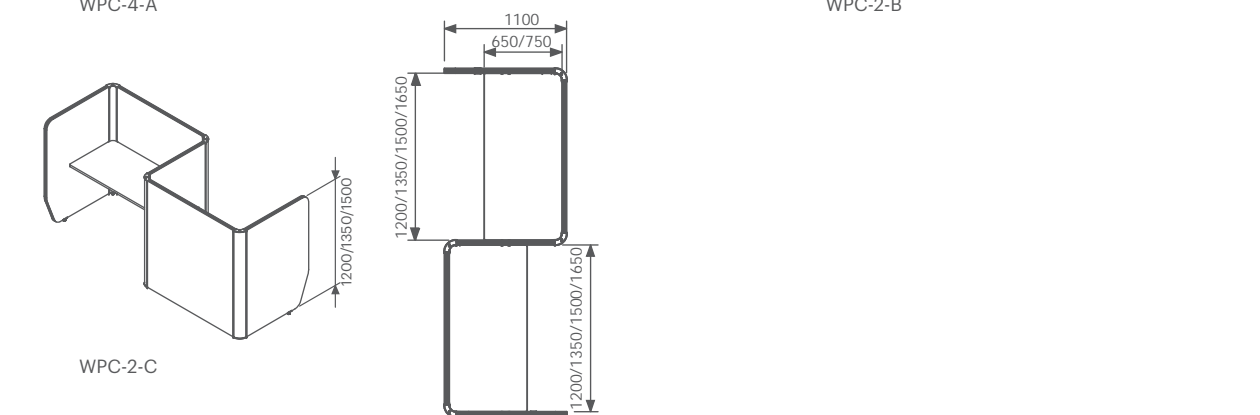
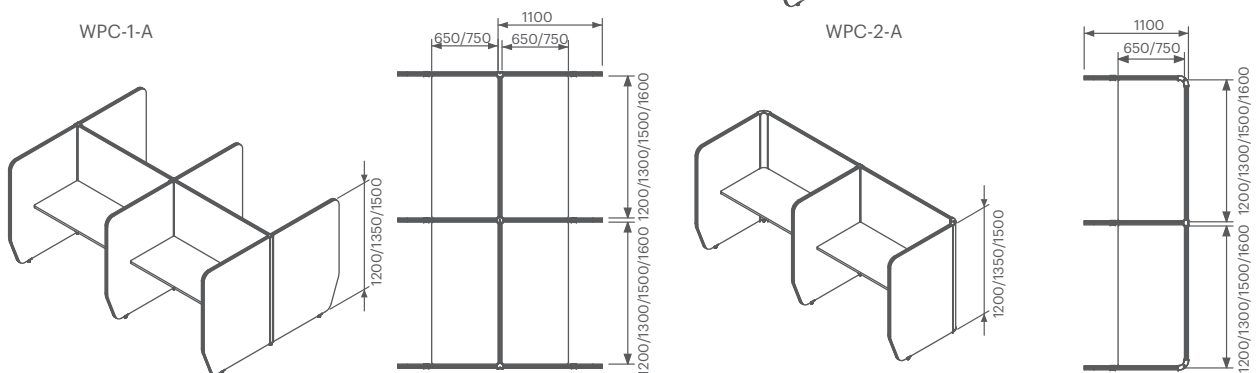
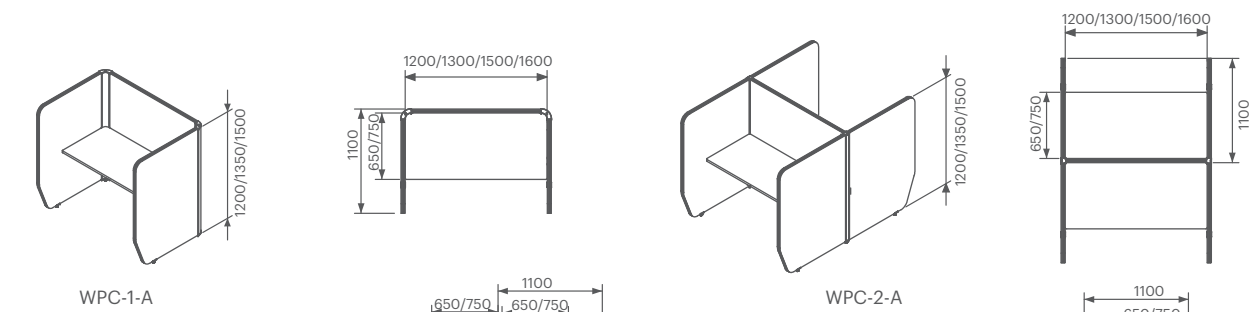

Workpod Hex

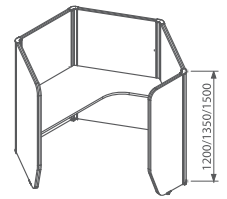

WPH-1-A

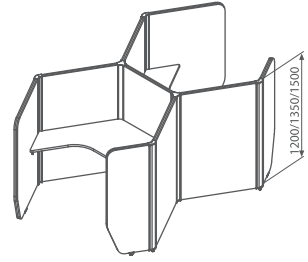

WPH-2-A

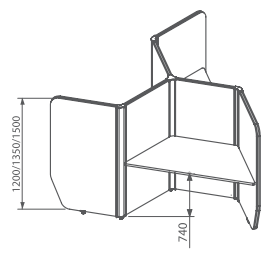

WPH-3-F

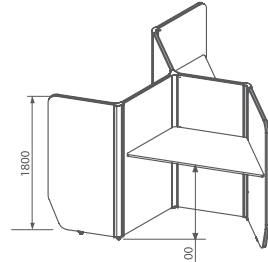

WPH-3-FH

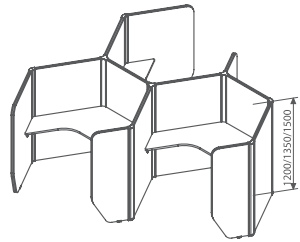
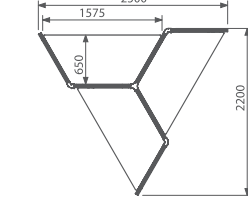
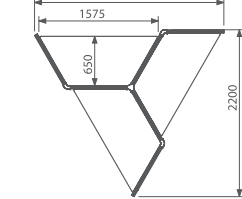
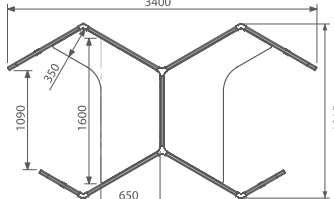
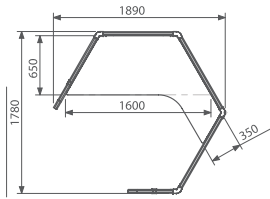

WPH-3-A

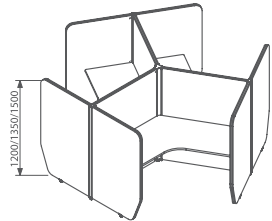

WPH-3-E

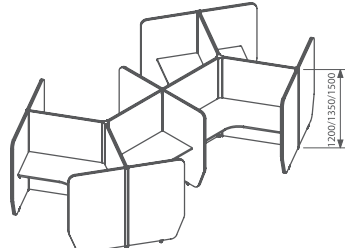

WPH-6-E

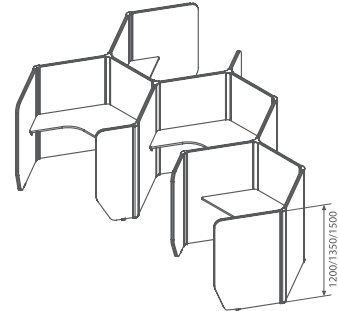

WPH-4-A

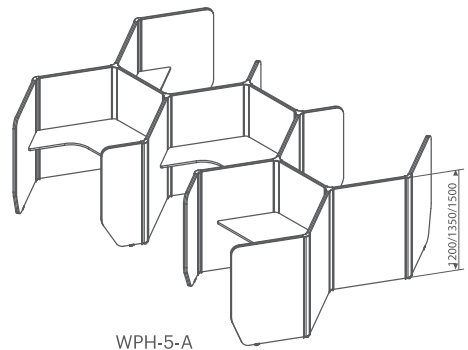
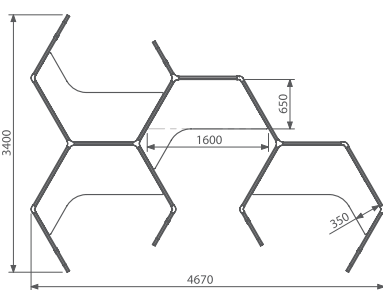
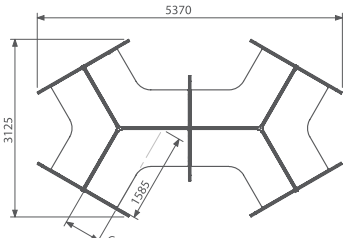
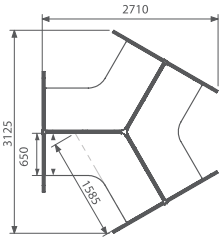
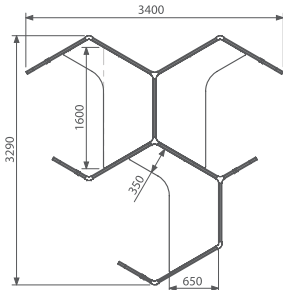

WPH-5-A

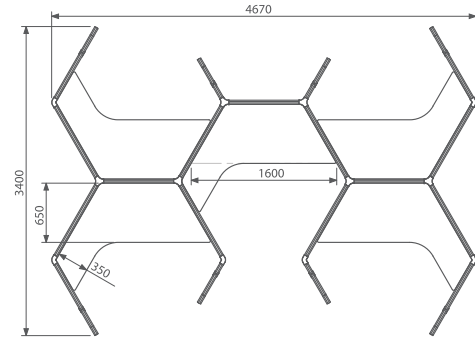

Workpod Wave

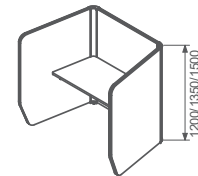

WPW-1-A

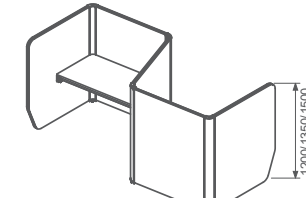

WPW-2-B

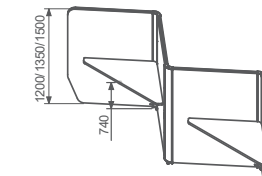

WPW-3-C

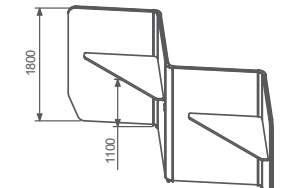

WPW-3-CH

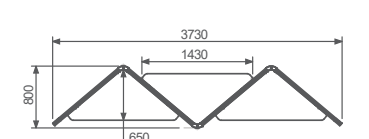
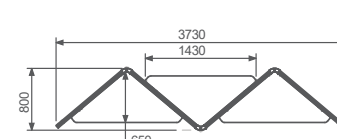
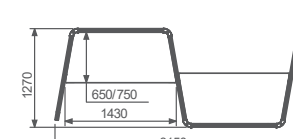
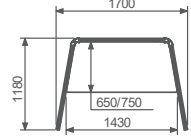

Meeting Pod

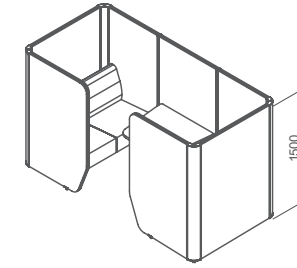

MP - 4 - B1

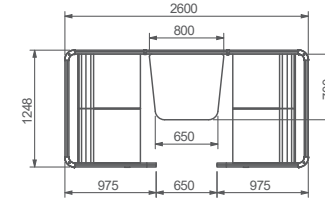

TOP VIEW

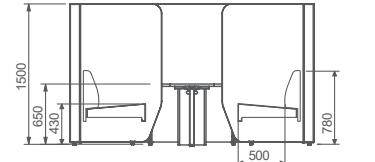

FRONT VIEW

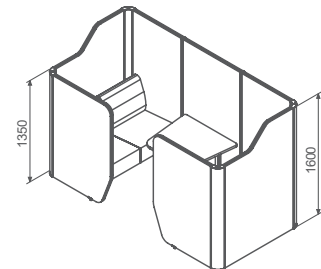

MP - 4 - B2

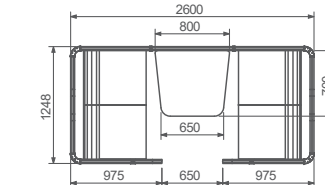

TOP VIEW

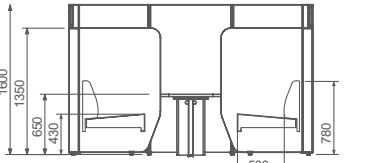

FRONT VIEW

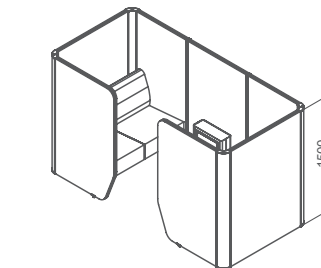

MP - 4 - C1

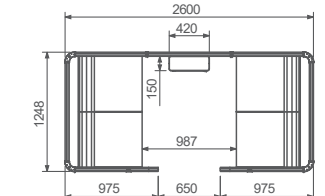

TOP VIEW

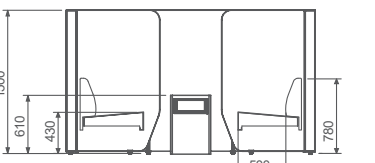

FRONT VIEW

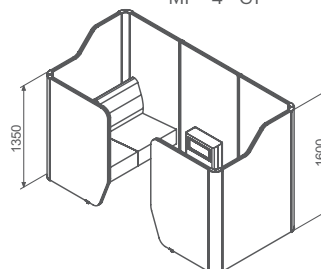

MP - 4 - C2

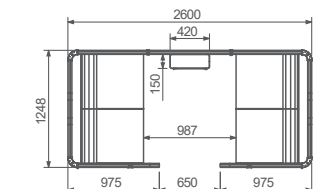

TOP VIEW

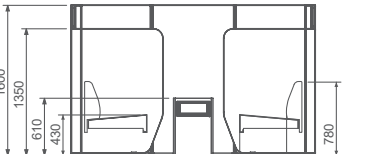

FRONT VIEW

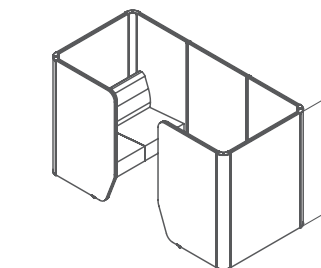

MP - 4 - D1

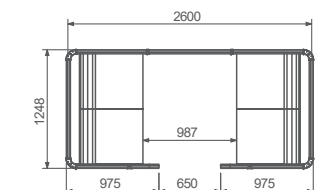

TOP VIEW

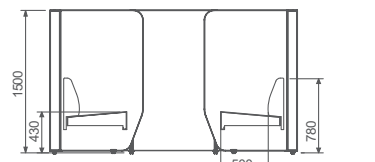

FRONT VIEW

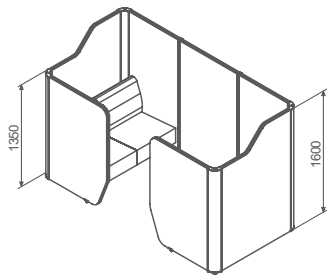

MP-6-D2

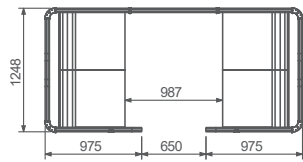

TOP VIEW

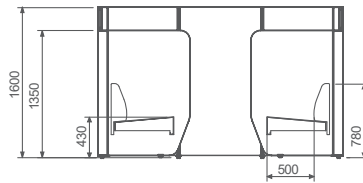

FRONT VIEW

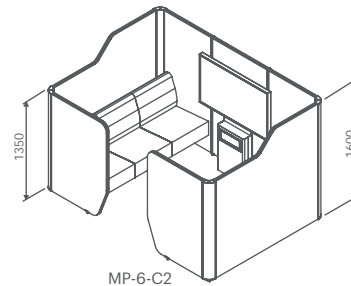

MP-6-C2

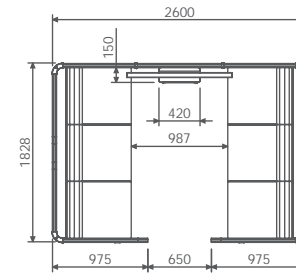

TOP VIEW

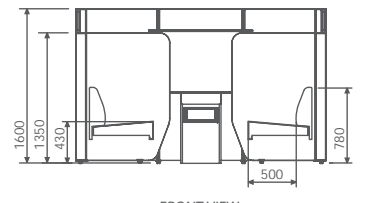

FRONT VIEW

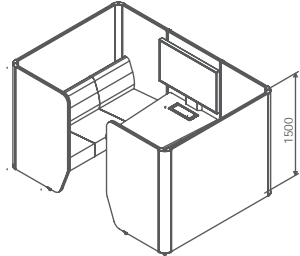

MP-6-A1

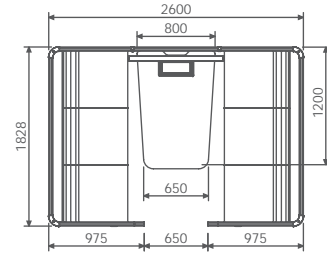

TOP VIEW

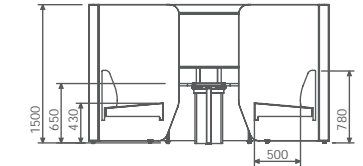

FRONT VIEW

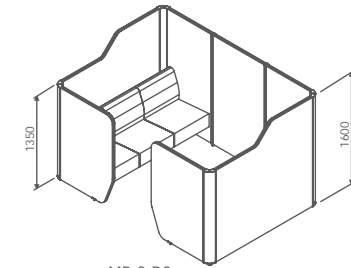

MP-6-D2

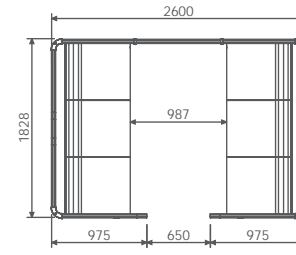

TOP VIEW

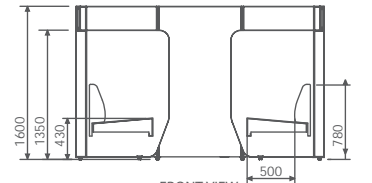

FRONT VIEW

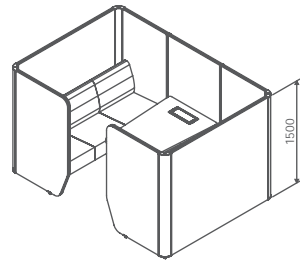

MP-6-B1

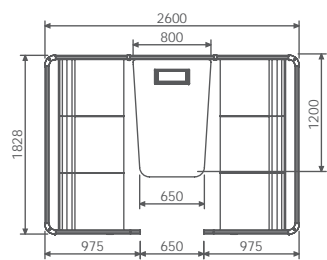

TOP VIEW

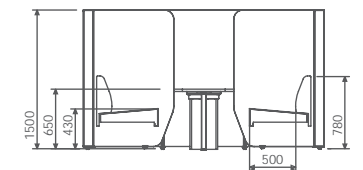

FRONT VIEW

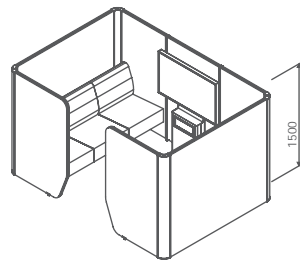

MP-6-C1

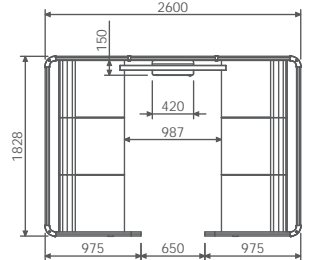

TOP VIEW

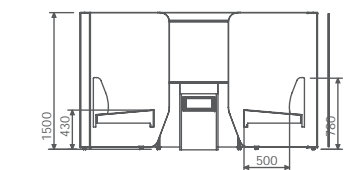

FRONT VIEW

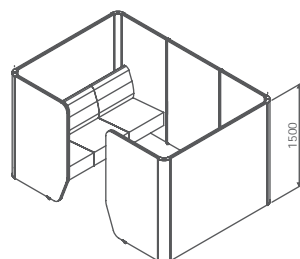

MP-6-D1

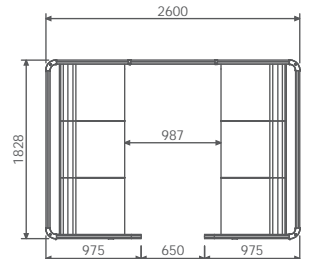

TOP VIEW

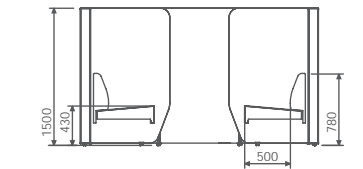

FRONT VIEW

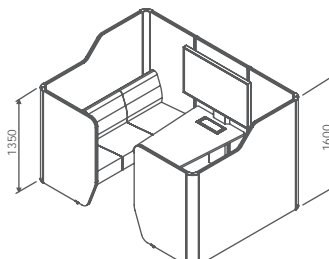

MP-6-A2

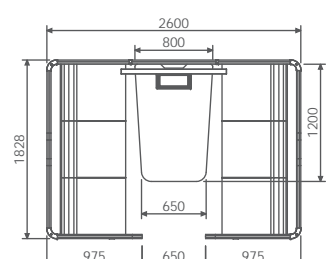

TOP VIEW

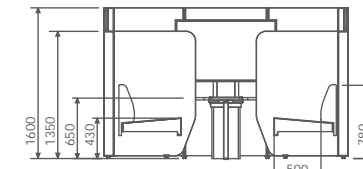

FRONT VIEW

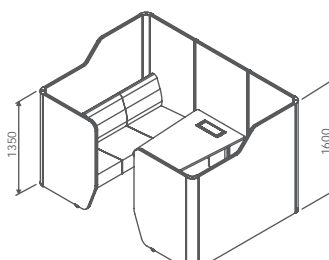

MP-6-B2

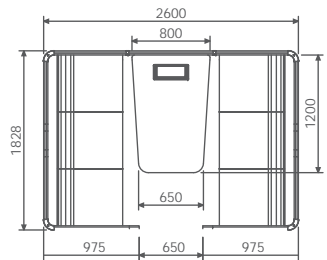

TOP VIEW

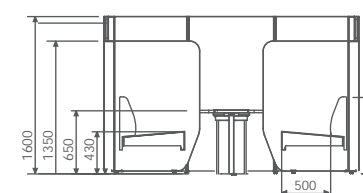

FRONT VIEW

Media Hub

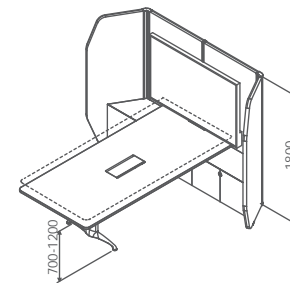

MH-W-HT

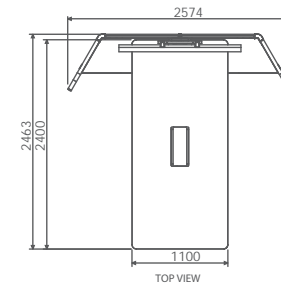

TOP VIEW

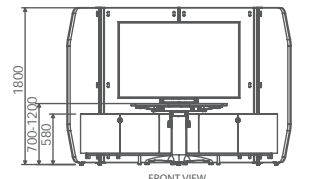

FRONT VIEW

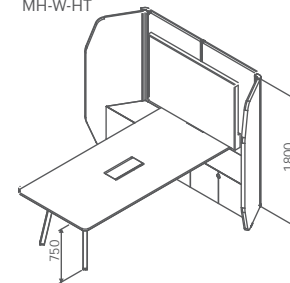

MH-W-FX

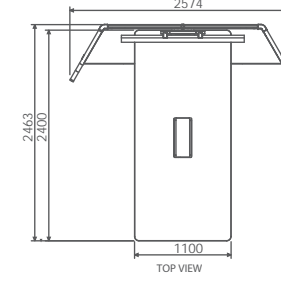

TOP VIEW

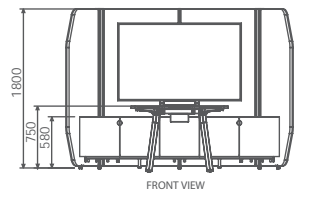

FRONT VIEW

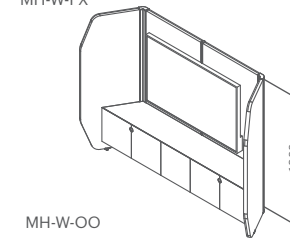

MH-W-OO

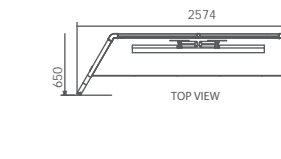

TOP VIEW

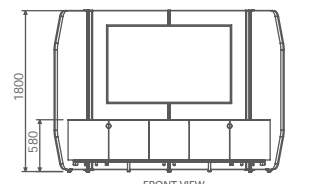

FRONT VIEW

Worktools

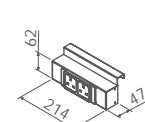

Seatpod Electrical Module (DCB-WT-A1)

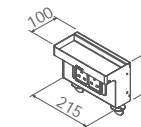

Workpod Electrical Module (DCB-WT-A2)

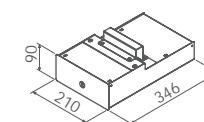

Mini Drawer (DCB-WT-A3)

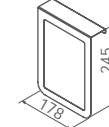

Pod Marker (Portrait) (DCB-WT-A4)

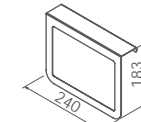

Pod Marker (Landscape) (DCB-WT-A4A)

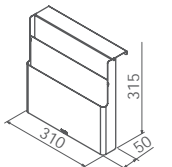

Document Holder (DCB-WT-A5)

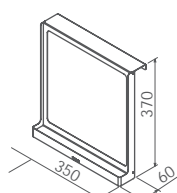

WhiteBoard (DCB-WT-A6)

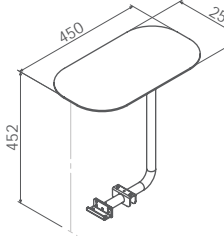

Seatpod Writing Tablet (Rotating Type) (DCB-WT-A7)

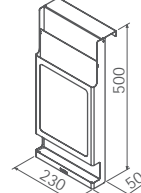

Organizer (DCB-WT-A8)

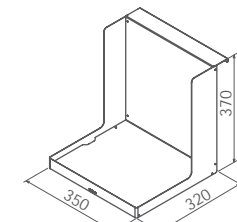

Files Organizer (DCB-WT-A9)

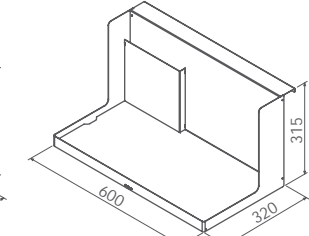

Multi Shelving (DCB-WT-A10)

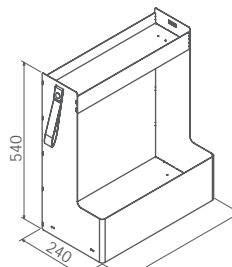

Caddy (DCB-WT-A11)

Technical Specification

SEAT POD SPW-2-0

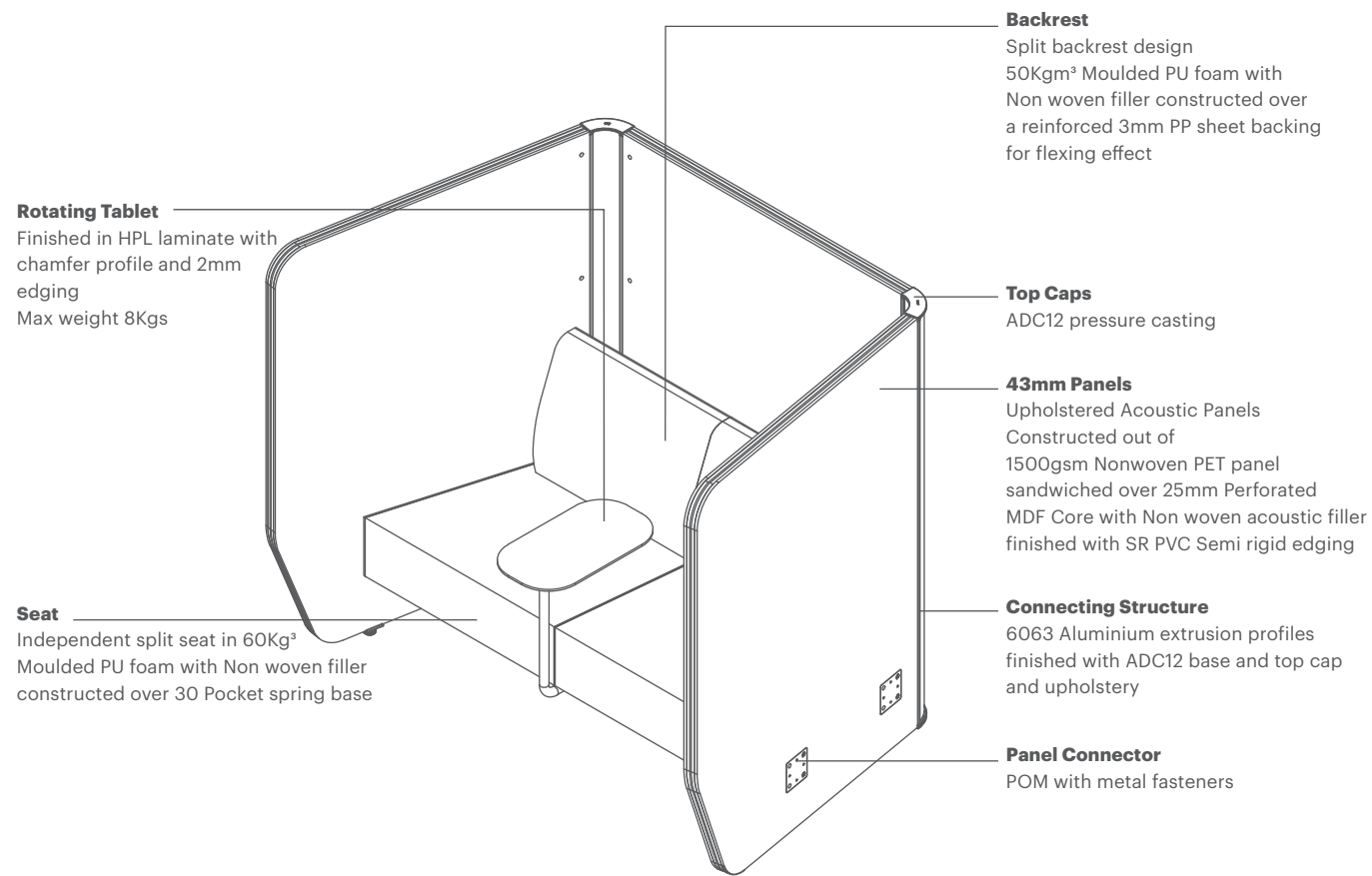

WORKPOD CUBIC WPC-1-A

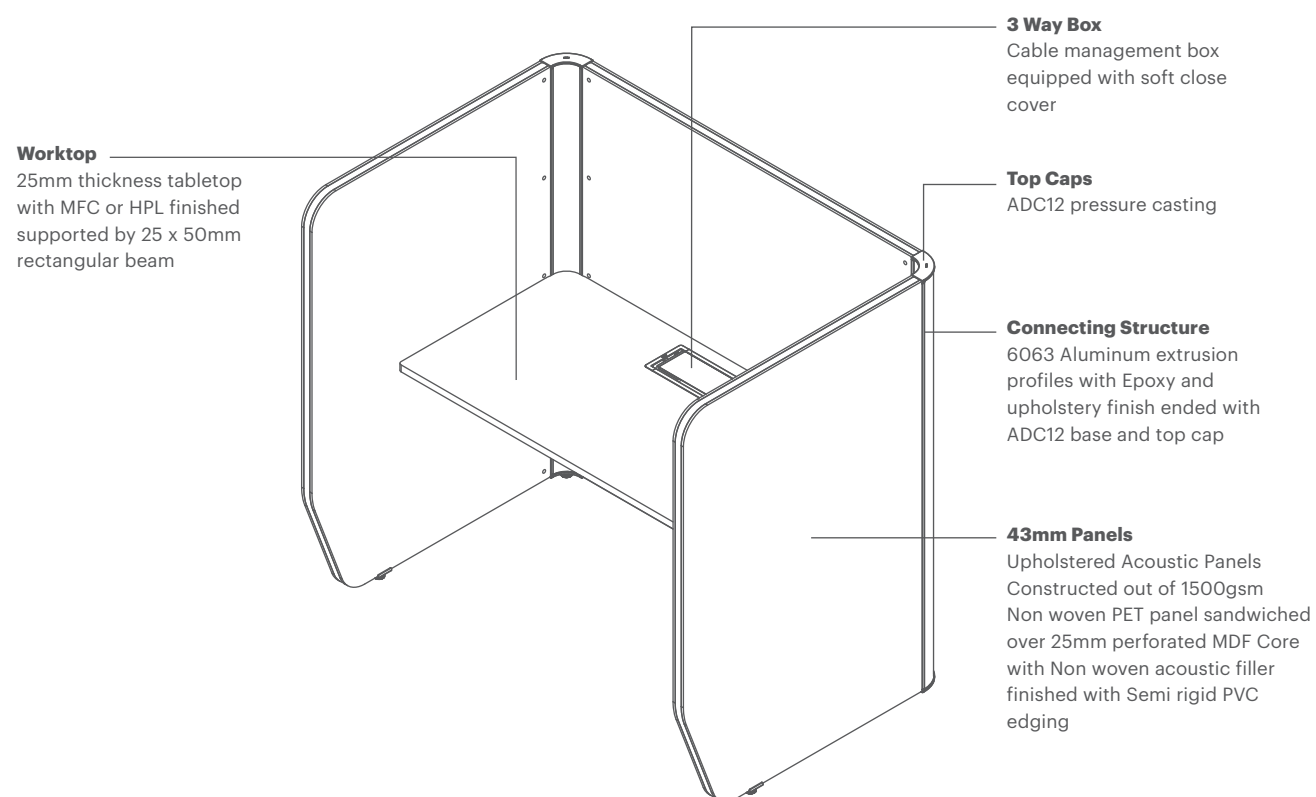

DESIGN

Decibel 43 is a system of ecologically sustainable modular composite panels.

Structural core

25mm thickness Medium Density Fiberboard (MDF) EO Grade. These are made from recyclable materials and are fully recyclable when disposed.

Acoustic Material

9mm thickness non-woven PET board, thermally and mechanically bonded 70% recycled material. Thermoplastics used to bond the boards are 100% recyclable and in order to facilitate single-variety separation and recycling, all plastic components that are large enough are labelled.

Upholstery

Covered in standard fabrics and finished with rubber beading - Polyester is used for cover fabrics and being a thermoplastic, it can therefore be remelted.

Fixtures and structure elements

Each panel is interconnected with T5-6063 grade aluminum profiles in epoxy finish and pressure casting aluminum caps and covers - Die-cast aluminium components are principally made out of remelted alloys which are largely recycled material. Remelted recycled aluminium offers an energy saving of 94% compared to the production of primary aluminium.

**Disclaimer: Please note that the above stated information is for reference purposes only. Specifications of the products and their material compositions may change without prior notice. Bristol Technologies holds no responsibilities as testing and readings are merely indicative figures provided by a third-party agency.*

PRODUCT COMPOSITION

Material	KG	Percentage %	Description
Corrugated Board	4	3.93	Packaging
Steel *	7.6	7.47	Frame & Structure
Aluminium *	3.1	3.04	Corner Connector
Plastic *	7.8	7.66	PET Acoustic Board
Wood *	76	74.72	Panel core
Others	3.2	3.14	Fabrics & Miscellaneous

Recyclable materials: 96.26% (* Symbol denotes Recycled material)

Decibel 43 is designed to facilitate the separation of its components and recycling.

Stated below are the design and manufacturing strategies implemented to deliver an ecologically sustainable product.

- **High degree of recyclability of the product.** Designed to be manufactured with 96% recyclable materials. Easy separation of product components.
- **Reduced wastage and energy.** Space optimization through low volume packaging. Removable and modular adaptable systems between different models.
- **Sustainable product.** Optimization of product life and 5 year warranty. Replacement of parts.
- **Environment friendly materials.** Recovery of unused paint in the process. Zero emissions of VOCs e.g. powder paint with no VOC emissions, water based adhesives for table set without VOC contents. Recycled cardboard packaging. Limitation on use of hazardous substances. Made without chromium, mercury, cadmium. EO Woods Board from recycled wood fibers.
- **Automated manufacturing process.** Adaptability and growth facilities.